

Compatibili con/Similar to
E1250; Z37; Z3154; EGF; RPM

Materiale/Material
Acciaio classe 5.8/5.8 class steel
Sfera completamente temprata lucida
Acciaio inox, lucido/
Sphere fully hardened polished
Stainless steel, polished

Trattamento superficiale/Finishing
Brunito/Burnished

A	B	C	D	Forze iniziali N	Forze finali N	
M4	9	0,8	2,5	6	12	•
M5	12	0,9	3	7	13	•
M6	14	1,0	3,5	9	15	•
M8	16	1,5	5	20	35	•
M10	19	2,0	6	25	45	•
M12	22	2,5	8	35	60	•
M16	24	3,5	10	65	110	•

Esempio ordine: CODICE + A
GS 4
GS4

* si realizzano misure su richiesta

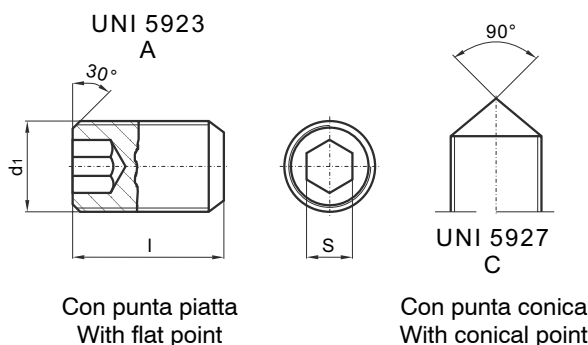

Grani tipo A
Socket set screws type A
Code/Code GA

Grani tipo C
Socket set screws type C
Code/Code GC

Compatibili con/Similar to
E1230; Z35; SN3600; EGR; RGPP; RGPCI

Materiale/Material
Classe 12.9/Class 12.9

d ₁	M3	M4	M5	M6	M8	M10	M12	M14	M16	M18	M20	M22	M24
S	1,5	2	2,5	3	4	5	6	6	8	8	10	12	12
L													
3	•												
4	•	•											
5	•	•	•										
6	•	•	•	•									
8	•	•	•	•	•								
10	•	•	•	•	•	•							
12	•	•	•	•	•	•	•						
14	•	•	•	•	•	•	•	•					
16	•	•	•	•	•	•	•	•	•				
18	•	•	•	•	•	•	•	•	•	•			
20	•	•	•	•	•	•	•	•	•	•	•		
25	•	•	•	•	•	•	•	•	•	•	•	•	•
30	•	•	•	•	•	•	•	•	•	•	•	•	•
35		•	•	•	•	•	•	•	•	•	•	•	•
40		•	•	•	•	•	•	•	•	•	•	•	•
45			•	•	•	•	•	•	•	•	•	•	•
50			•	•	•	•	•	•	•	•	•	•	•
60				•	•	•	•	•	•	•	•	•	•
70					•	•	•	•	•	•	•	•	•

Esempio ordine: CODICE + d₁ x L
GA 3 x 3 GC 5 x 12
GA33 GC512

* si realizzano misure su richiesta